

# MBP8 Series

## Pen-type LVDT

### Applications

SPC automated data collection  
On-line parts inspection  
Process standard monitoring  
Industrial Automation Gauge  
Material Testing

### Features

8mm diameter  
Precision linear ball bearings  
Repeatability <0.15um  
Industry standard dimensions and  
measurements Service life NLT 20 million  
full-pressure measurements



The MBP8 series 8mm diameter pen type LVDT is designed for high precision industrial measurement, quality control and SPC statistical process analysis applications. The product adopts a structure combining linear ball bearings and a hardened non-rotating measuring shaft, effectively reducing radial play and edge load interference, and realizing repeatable positioning accuracy of up to 0.15µm.

The LVDT measuring head has a built-in frictionless structure, and its core is directly connected to the measuring shaft, which can output a voltage signal that is linearly proportional to the displacement, effectively avoiding measurement errors caused by mechanical friction or hysteresis. The output signal is compatible with all kinds of standard signal conditioning equipment and can be conveniently connected to display instruments or computer data acquisition systems.

In conventional applications, the measuring shaft is continuously pushed by a spring with a force of approx. 70 grams, which extends it outwards from the mechanical zero point and ensures stable contact with the object to be measured. The entire measuring mechanism, including bearing, measuring shaft and LVDT, is integrated in a compact and robust stainless-steel housing with a diameter of only 8 mm. The end is equipped with a flexible polyurethane protective cable, which is resistant to stretching and abrasion and guarantees stable signal transmission to the conditioning system.

MBP8 series LVDTs are the ideal solution for precision displacement measurement with their miniaturized design, high accuracy output and anti-interference capability.

In order to facilitate the actual application of the customer, we also supply a variety of accessories to match the LVDT, the series of related mounting fixtures, signal processing equipment, cables and other accessories, please contact us for information.

## Electrical Specifications

	Specification
Input voltage:	3V rms (nominal)
Input frequency:	5 kHz (nominal)
Linearity error:	<±0.25% (Full stroke)
Repeatability error:	<0.15µm
Lifespan:	>20 million cycles
Operating temp.:	-10°C to +80°C
Thermal Coefficient	-0.01%/°C (nominal)
Vibration:	20g, 2 kHz

## Wiring Connection

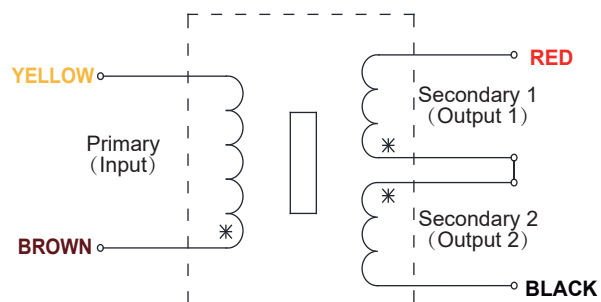

## Dimensions

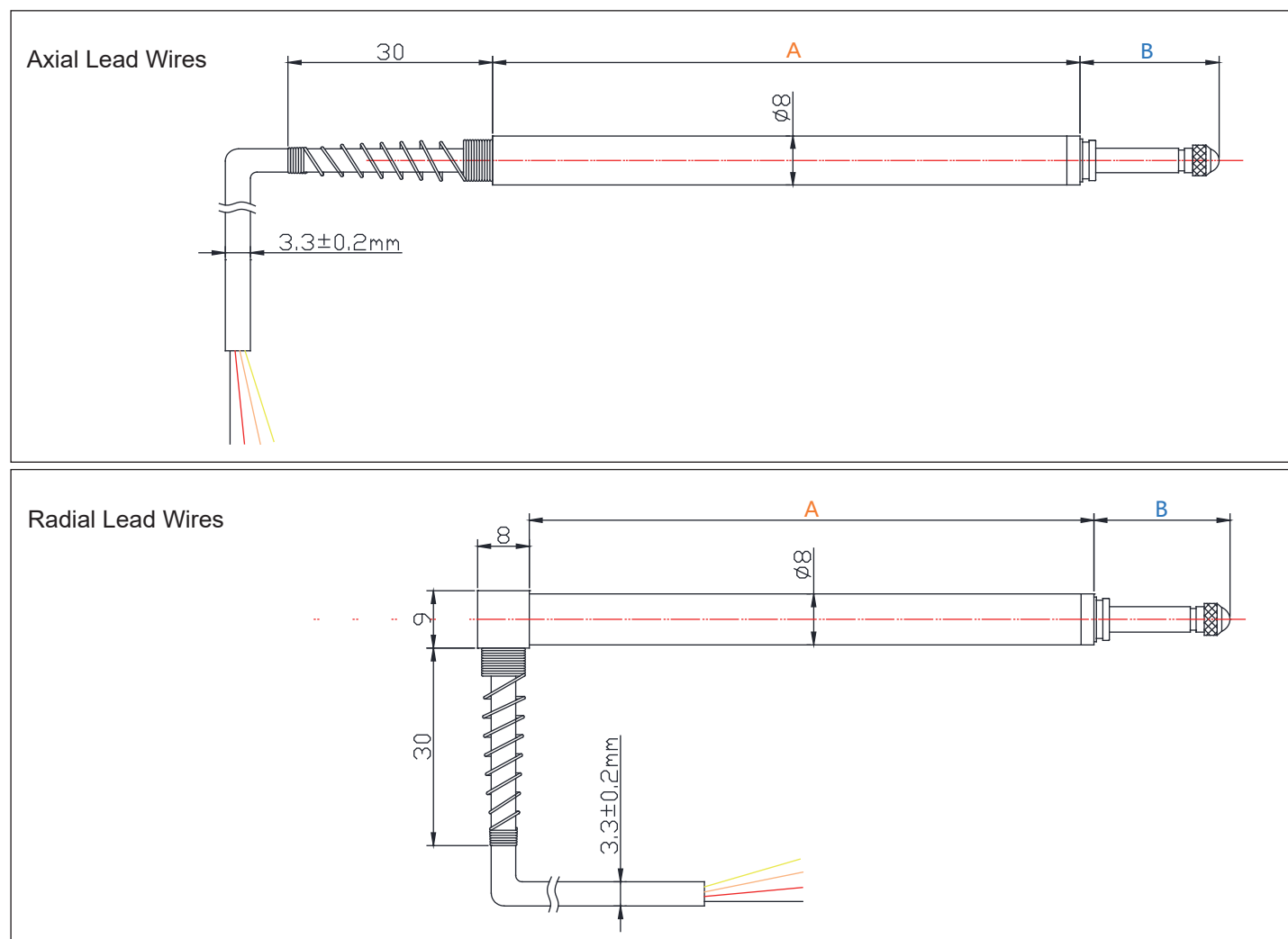

Parameter	Model →	MBP8-01	MBP8-02	MBP8-05	MBP8-10
Ranges	mm	±0.5	±1	±2.5	±5
Body Length "A"	mm	31.2	48	68	91
Shaft Extension "B"	mm	8	14	17.6	25.5
Pre-travel	mm	0.15	0.15	0.15	0.15
Over-travel	mm	0.5	0.5	0.85	0.85
Sensitivity	mV/V/mm	210	210	150	100

## Ordering Guide

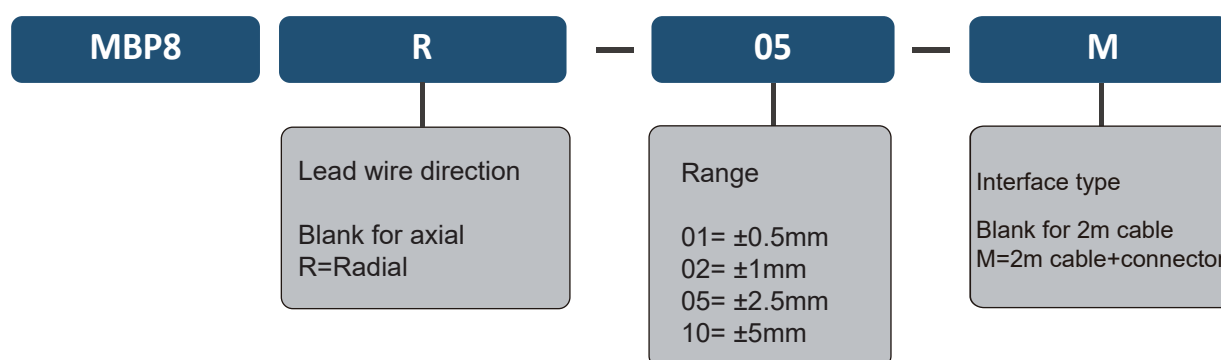

LVDT Model No.		
Ranges	Model No.	P/N
0-1mm LVDT	MBP8-01	0356-0606
0-2mm LVDT	MBP8-02	0356-0607
0-5mm LVDT	MBP8-05	0356-0608
0-10mm LVDT	MBP8-10	0356-0609

CONNECTOR Model No.		
Ranges	Model No.	P/N
0-1mm LVDT	MBP8-01-M	0356-0606-01
0-2mm LVDT	MBP8-02-M	0356-0607-01
0-5mm LVDT	MBP8-05-M	0356-0608-01
0-10mm LVDT	MBP8-10-M	0356-0609-01

## Accessories

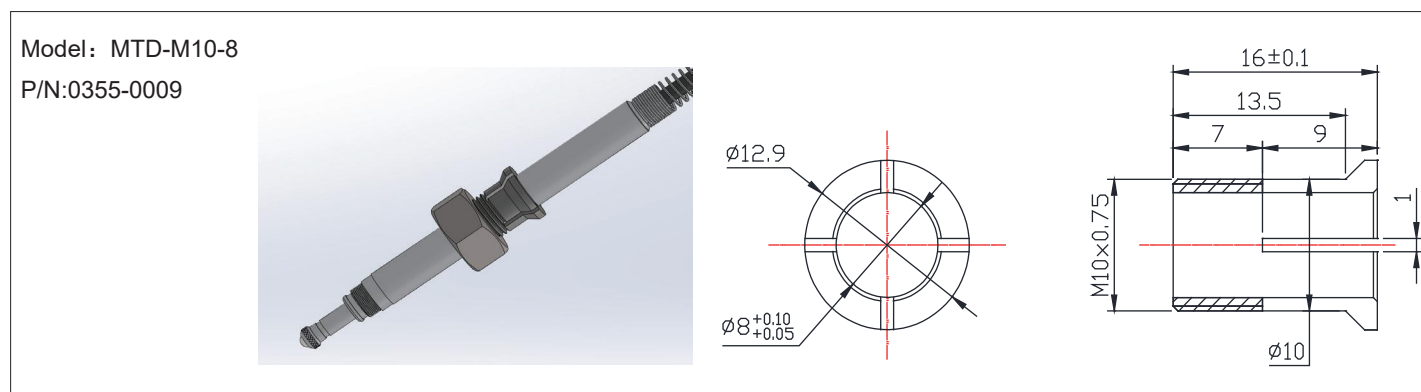

P/N	Part Name	Model No	Remarks
0356-0009	Bracket	MTD-M10-8	For pen-type LVDT only

## Contact Us

Contact us for technical consultation or customization requests.

Hotline: 400-013-6886

Tel: 010-51660768

Fax: 010-80766992

Email: [info@abeksensors.com](mailto:info@abeksensors.com)

Homepage: [www.bjabek.com](http://www.bjabek.com)

ABEK SENSORS is a registered trademark. We reserve the right to change the specifications of our products.

Copyright ©2017 -ABEK SENSORS